

The logo for SPXX, featuring the letters 'SP' in a dark grey, bold, sans-serif font, followed by 'XX' in a bright green, bold, sans-serif font. A registered trademark symbol (®) is located to the right of the second 'X'.

SPXX®

A green arrow icon pointing to the right, positioned to the left of the tagline text.

Where Ideas Meet Industry

Plenty



G2000

G2000- SLIDING VANE PUMP

Plenty Mirrlees Pumps

LUBRICANTS BLENDING

G2000



G2000 Lubricants Transfer Pump connected to piping with compressed air purge and pigging system.

- BASE OIL TRANSFER
- SHEAR SENSITIVE ADDITIVES
- TANK RECIRCULATION BLENDING
- BLENDED OIL TRANSFER
- GREASE
- TRUCK LOADING *
- BARGE LOADING *
- DRUM FILLING *
- BOTTLE/CAN FILLING MACHINES *

*see also U2000 variable flow pump range with CPC.

Liquid products ranging in viscosities from 30 ssu to 350,000 ssu are handled with a G2000 vane pump, with mechanical seals used for most applications.

■ Standard pumps - heavy duty industrial

The G2000 standard pumps are built of cast iron or steel case construction according to clients preference, and can be fitted with integral relief valve, and heating jackets as necessary for the duty.

■ API 676, and other specifications

The G2000 Pumps can be supplied in accordance with the requirements of API 676. Other international pump standards, or client specific requirements can be accommodated.

■ Unitisation

Pumps can be supplied as bare shaft or fully assembled with driver on a baseplate (API or Industrial design), with spacer or non-spacer coupling, and non-spark guard.

BITUMEN & ASPHALT

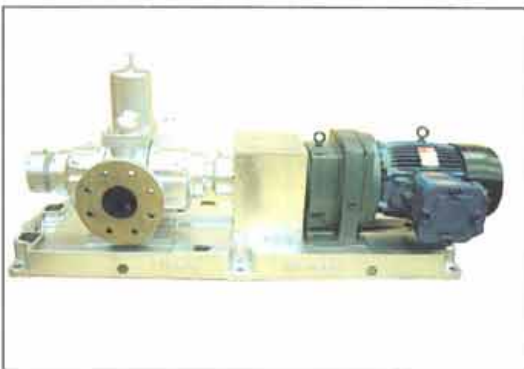

G2000 Pump with integral Heating Jackets and high temperature paint finish.

- TANK TO TANK TRANSFER
- IN-LINE BLENDING
- TRUCK LOADING*
- BARGE LOADING*
- DRUM FILLING*
- BITUMEN EMULSION
- ORIMULSION
- STANDARD CONSTRUCTION UP TO 570°F

*see also U2000 variable flow pump range with CPC.

The Plenty rotary vane pump is able to perform continuous pumping during temperature changes where centrifugal pumps normally fail. For applications up to 390°F it is normal to use an internal bearing pump with only 1 mechanical seal. (2 seals on higher temp external bearing pumps).

G2000 HEAVY DUTY SLIDING VANE PUMP

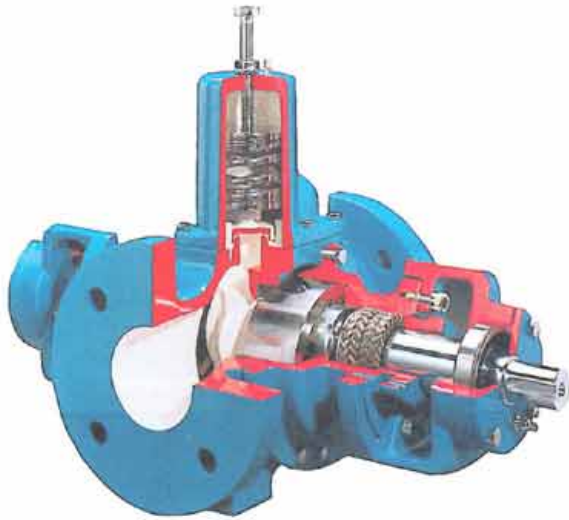

Standard pump assembly options include:

- INTERNAL OR EXTERNAL ROLLER BEARINGS.
- INTERNAL SLEEVE BEARINGS
- MECHANICAL SEAL OR GLAND PACKING
- SEAL FLUSH AND/OR QUENCH IF REQUIRED
- SINGLE OR DOUBLE MECHANICAL SEALS. CARTRIDGE SEALS IF SPECIFIED
- CAST AND FABRICATED BASEPLATES, WITH DRIP RIM AND DRAIN FACILITY IF REQUIRED
- INTERNAL PRESSURE RELIEF VALVE (EXCLUDED/BLANKED OFF, FOR API 676 SERVICE)
- JACKETED CASINGS FOR HIGH TEMPERATURE DUTIES
- HARDENED ROTATING ASSEMBLY (NITRIDING) FOR ARDUOUS SERVICES

THE ROTATING ASSEMBLY

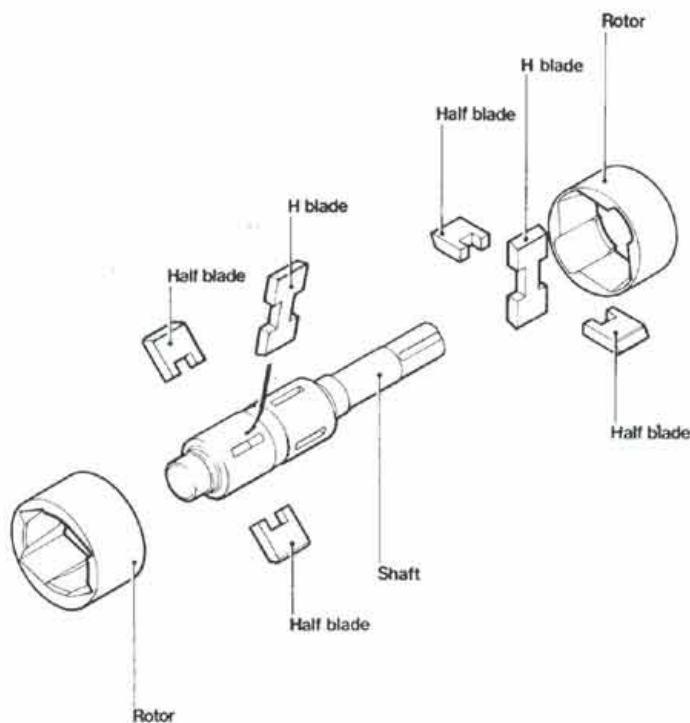

The unique rotating assembly consists of eight working blades made up as two sections set 45° apart, each section consisting of two half blades and one "H" blade.



The photograph shows only one rotor and the roller bearings used on an inboard pump.

Pump Features

& User Benefits

Plenty vane technology

The Plenty pumping principle has less wear and lower maintenance than conventional vane pump design technology.

Versatile design concept

Standard pump arrangements suitable for viscosity applications from 30 ssu to 350,000 ssu (for higher viscosities, contact Plenty Ltd)

Robust construction

Heavy duty bearing arrangement designed for long operational periods between routine maintenance.

Double Suction

Low NPSH required characteristics

Slow running

In addition to long service life, the slow pumping action has a very low shear rate, dramatically reducing or even eliminating emulsification of the pumped liquid.

Low noise

Environmentally acceptable for site operators

High volumetric efficiency

Low running costs.

Self draining

Zero retention, avoids cross contamination when installed for multi product service.

Viscous Pumping

Unlike some other vane pumps, the Plenty vane and blade assembly enables the pump to operate at high viscosities whilst maintaining high efficiency.

Mechanical Seals

The seal housing is in accordance with the standard dimensions of DIN 24960, and can therefore accommodate most brands of mechanical seals.

Heating Jackets

The pump can be fitted with jacketed covers to allow heating by hot oil or steam. (electric heat tracing can be used on non jacketed pumps)

2000 Series parts Interchangeability

G2000 pumps use identical rotors and blades from the U2000 pump range, offering maximum parts interchangeability.

Relief valve

All G2000 pumps can be fitted with an internal pressure relief valve to protect the pump from excess pressures.

API 676

Refinery specifications and client special requirements can be accommodated.

THE PUMPING PRINCIPLE

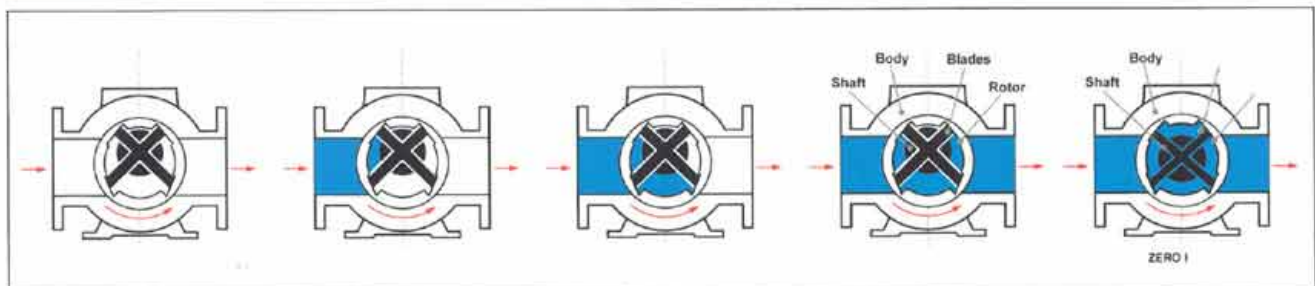

The eccentricity between the shaft and rotor causes the chambers formed between the rotor and blades to vary in size as the pump rotates. The liquid entering the pump is guided into the ends of the rotor and then back out through the discharge port.

There are eight pumping sectors and the illustration shows how the sector increases and decreases in size during rotation. Each sector in turn acts in the same manner, causing the continuous pumping action.

Unlike a conventional vane pump the blade tip is not rotating at high peripheral speeds against a liner (which could cause rapid wear to the blade tip). The G2000 blades are gently sliding along a flat inside the rotor, thus reducing wear and maintaining high volumetric efficiency.

This pumping principle has a low shear rate which is important for blending lube oils or pumping shear sensitive fluids such as oily water mixtures to a separator for example.

*NOTE. The smallest pump model G2000-10 (2") incorporates single suction 4 blade design due to small flow rates and corresponding compact construction.

VISCOUS FLUIDS



G2000 Pump with Heat Tracing prior to lagging.

- POLYMERS
- RESINS
- ADHESIVES
- HEAVY FURNACE OILS
- MOLASSES*
- EDIBLE OILS
- VARNISH
- INKS
- DISTILLATE FUELS

*For massecuite duty, see Magmo Pump Range

Viscous fluids up to 350,000 ssu are handled with a standard pump, and viscosities in excess of 2,000,000 ssu with a factory modified pump and sealing arrangement.

■ Non standard pumps

The G2000 pump design can be factory modified for extremely viscous, or arduous refinery, applications. Materials of construction are selected according to the fluid nature.

■ Specialist Sealing

Special sealing options are available including single, double and tandem arrangements, in component or cartridge configuration.

■ Sealless Magnetic Drive

When single or double mechanical seals are not able to provide a safe seal arrangement then a U2000 pump with magnetic drive should be selected.

CHEMICAL



G2000 Pump in Bronze/Stainless Steel construction.

- FATTY ACIDS
- VISCOUS CHEMICAL ADDITIVES
- ACETATE DOPE
- VISCOSE
- POLYMERS
- RESINS
- SOAPS / SOAP STOCKS
- POLYOLS

Materials of construction range from basic Cast Iron / Steel, to NI-Resist, Bronze and Stainless Steel Alloys, to ensure compatibility with the fluid to be pumped.

G2000

FLOW RANGE

(Pump frame size is nominal design flow in M³/Hr. e.g. G2000-40 is nominally a 40M³/Hr Pump).

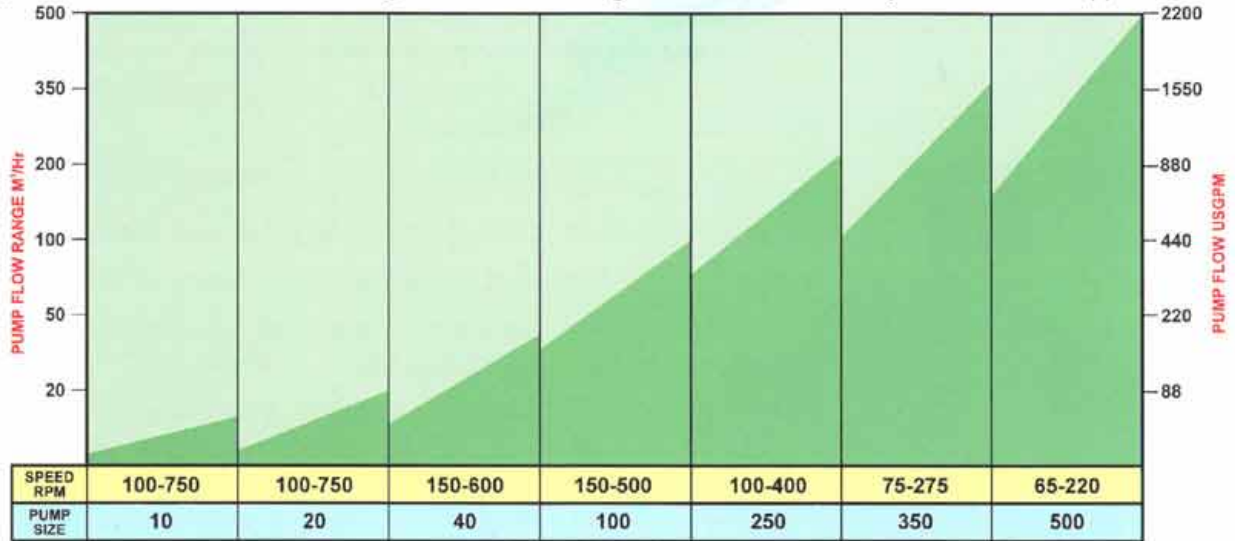

APPROXIMATE DIMENSIONS

PUMP SIZE	10	20	40	100	250	350	500	Standard flanges are to ANSI dimensions IRON - ANSI 150FF and 250FF. STEEL - ANSI 150RF and 300RF.
SUCTION	2"	3"	4"	6"	10"	12"	14"	
DISCHARGE	2"	3"	4"	6"	8"	10"	12"	

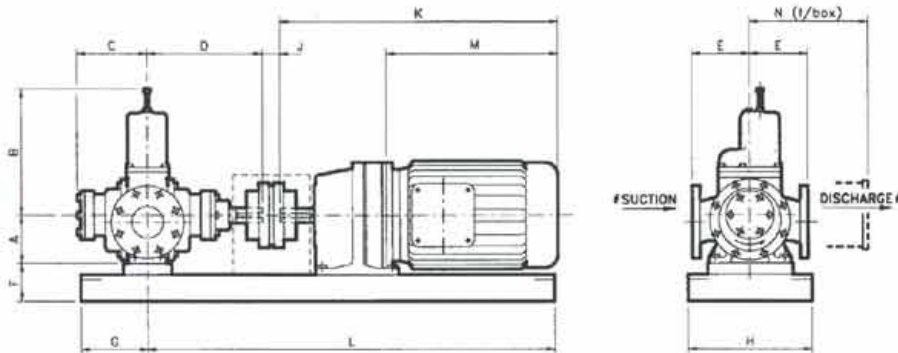

*Pumps can be constructed with suction left (as shown) or suction right, to suit installation.

Approximate dimensions (inches). DO NOT use for installation purposes.

PUMP SIZE	PUMP ONLY				UNIT					*ELECTRIC MOTOR				
	A	B	C	D	E	F	G	H	J	FRAME	K	L	M	N
10	4.72	11.25	6.34	11.06	5.83	5.10	5.12	12.00	1.42	145T	17.91	24.80	10.15	9.00
										215T	26.14	28.55	16.95	11.40
20	4.72	12.00	6.61	11.06	5.83	5.10	6.30	17.00	1.57	145T	19.37	30.50	10.15	9.00
										256T	33.90	45.25	22.00	12.45
40	6.00	16.73	8.66	14.13	7.48	5.50	8.00	21.25	2.00	182T	22.36	36.40	13.15	9.50
										324T	45.20	59.05	29.50	14.55
100	7.90	18.82	11.65	19.30	9.65	5.50	11.80	27.55	2.36	213T	29.60	49.20	16.95	11.40
										365T	55.42	78.75	30.20	19.50
250	10.63	29.25	14.30	25.75	12.91	6.50	17.72	29.53	3.00	256T	37.67	61.00	22.00	12.45
										449T	56.10	80.70	42.65	21.45
350	20.10	31.00	19.10	31.89	18.00	8.25	21.65	34.45	5.50	364T	51.45	84.65	28.22	19.15
										449T	82.90	118.10	42.65	21.45
500	20.10	33.00	26.10	37.20	22.64	8.25	27.56	39.37	5.50	445T	67.85	108.25	40.35	20.15
										449T	95.50	133.90	42.65	21.45

*Dimensions are given for the smallest and largest motor sizes for each pump. Larger pumps may be supplied with separate gearbox and motor arrangement.

G2000



Global Headquarters
13515 Ballantyne Corporate Place
Charlotte, North Carolina 28277
United States

Where Ideas Meet Industry

Where Ideas Meet Industry

www.spx.com